

INSTALLATION OF LOOSE LAY VINYL

The installation of:

6.1 LOOSE LAY VINYL SHEET

6.12 LOOSE LAY VINYL TILES & PLANKS

6.21 INTERLOCKING TILE & PLANK SYSTEMS

6.1 LOOSE LAY VINYL SHEET

6.2 RECEIPT & STORAGE

- ▶ On receipt of rolls, check that colour references correspond to those ordered, that quantities are correct and that there is no damage.
- ▶ In particular, check that rolls are from one batch, if that was requested on the order.
- ▶ On arrival at site, the rolls should be safely secured, positioned and stored in accordance with the directions on the roll label at a minimum temperature of 18°C for at least 48 hours prior to installation.
- ▶ To achieve best results, site conditions should be as described in BS 8203 or prevailing local/national standards. A constant working temperature between 18°C and 27°C should be maintained for at least 48 hours prior to installation, during the installation and for 48 hours afterwards.

6.3 LOOSE LAY CONDITIONING

- ▶ Polyflor Loose Lay Vinyl sheet requires conditioning ahead of installation. Conditioning should be carried out in the same areas as the installation, to prevent thermally induced dimensional changes.
- ▶ Conditioning should ALWAYS take place in the area that is to receive the installation.
- ▶ The conditioning time should be increased to at least 48 hours where the sheet has been stored outside or stored/delivered at temperatures below 10°C.

6.4 PRIOR TO INSTALLATION (UNDERFLOOR HEATING)

On installations where underfloor heating is used:

- ▶ The system should be fully tested and commissioned prior to the flooring installation commencing.
- ▶ Underfloor Heating systems should be switched off and be fully cooled for a minimum of 48 hours prior to the installation commencing. The system should remain off and fully cooled during the installation and for a minimum of 48 hours afterwards. Then slowly bring back up to the working temperature incrementally over several days.
- ▶ A maximum subfloor temperature of 27°C should never be exceeded.

6.5 PREPARATION OF WORK AREA

- ▶ The work area should now be prepared to receive the sheet flooring. Ensure that all other trades have completed their work and removed all their equipment and materials.

KEY POINT

Commencement of work is deemed by many as acceptance of the site conditions as suitable for laying floor coverings.

- ▶ Remove all debris and sweep or vacuum the whole floor area. Check the condition of the subfloor and make good as necessary.
- ▶ Stone or power grind any cementitious subfloor to remove any 'nibs' or ridges.
- ▶ Sweep or vacuum again prior to laying.
- ▶ If required by the contract, or if in doubt, check the moisture content of the subfloor and record the results and method used.
- ▶ Good lighting is essential.

6.6 LAYOUT OF LOOSE LAY VINYL SHEET

- ▶ The architect may have provided a drawing showing the direction in which the material should be laid. In this case, lay the sheet as directed.
- ▶ On installations where the architect has left this to the discretion of the flooring contractor; at the tender stage show in which direction the material will be laid and state that your estimate is based on this.
- ▶ If a joint is necessary always pay particular attention to where seams will fall, avoiding such occurrences as seams in the centre of doorways. If large windows are installed, minimise the effect of the joints by laying towards the window.
- ▶ For large areas over 20m² where a joint will be necessary or where rolling loads are likely, Polyflor recommend that the vinyl is fully bonded to the subfloor with a recommended adhesive from the Polyflor Approved Adhesive list.



Further information on fully bonded installation instructions can be found in Section three.

6.7 SLABBING THE SHEET

- ▶ Polyflor recommends that all Polyflor sheet flooring be rolled out face upward, taking care not to damage the surface, and cut approximately to size.
- ▶ Allowance of at least 75mm should be made at the ends for trimming in, the slabs should then be left overnight for 24 hours, to condition at a consistent temperature range between 18°C and 27°C.

6.8 FITTING THE FIRST LENGTH

- ▶ Place the first sheet in position next to the wall with the outer edge approximately 15mm from the nearest point.
- ▶ Adjust the lie of the sheet so that the inner edge is parallel with the axis of the room (Figure 6.1).

KEY POINT

A 2mm gap must be allowed around the perimeter of the room

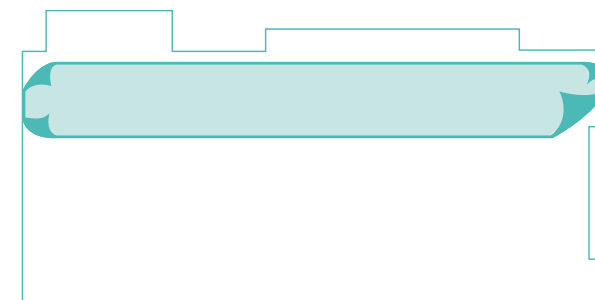

Figure 6.1 Lining up the first sheet

- ▶ Depending upon the depth of the recesses, either a bar scriber or a pair of scribers should be used to trace the profile of the wall. The scribers should be set to allow for the deepest recess or rake of the wall. The scribers should be set to allow for a 2mm expansion gap around the perimeter.
- ▶ Holding the scribers vertically and square to the edge, trace the wall profile onto the face of the sheet (Figure 6.2).

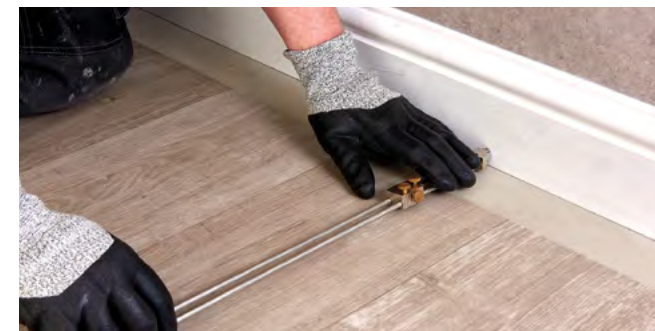

Figure 6.2 Scribing the wall profile

- ▶ Care should be taken when using the wider widths of loose lay sheet (3m or 4m) not to fully fold the sheet over itself when fitting into recesses and against walls as this can lead to pressure marks that might not relax out following installation.
- ▶ With this method, all irregularities of the wall will be accurately reproduced onto the surface of the sheet. If, because of the colour or decoration, the scribed line is difficult to see, rub suitably contrasting chalk dust into the line to highlight it.
- ▶ Ease the sheet away from the wall and, using a hook blade trimming knife, cut off the excess material to the scribed line.
- ▶ Slide the sheet back against the wall and check the fit, making any minor adjustments as necessary.

- ▶ When satisfied that the fit on the first edge is correct, use a pencil to trace the opposite edge onto the subfloor (line A-B in Figure 6.3).
- ▶ In the centre of the room, draw a line on both the sheet and subfloor square to the main axis of the sheet (line C-D in Figure 6.3).
- ▶ Keeping the inner edge of the sheet on line A-B, slide the sheet back to clear the wall at one end of the room.

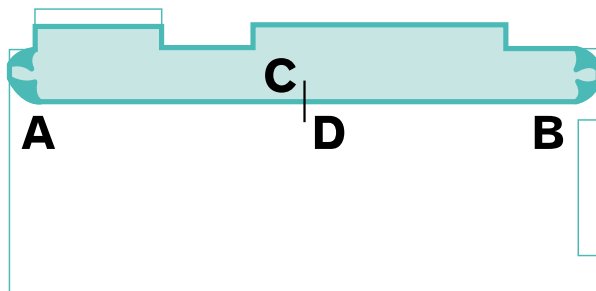

Figure 6.3 Marking the position

- ▶ Set the scribers to the distance now between lines C and D (Figure 6.4) allowing for a 2mm expansion gap.
- ▶ Trace the end wall profile and cut to fit as described in preceding paragraphs. Repeat for the other end of the sheet.



Figure 6.4 Scribing the wall profile

6.9 FITTING SUBSEQUENT LENGTHS

6.9.1 Alignment of decoration

- ▶ This type of floor covering features a print layer with a regular, repeat decoration (e.g. wood plank). It is important that care is taken to align the pattern decoration of each adjacent sheet.
If in any doubt contact the [Polyflor Customer Technical Services Department \(CTSD\)](#) for further advice on +44 (0) 161 767 1912.

- ▶ The label and printed information on the backing of the sheet must be checked and the product reverse laid when instructed.

6.10 CUTTING IN THE SEAMS

Polyflor recommends that all vinyl sheet floor coverings are welded.

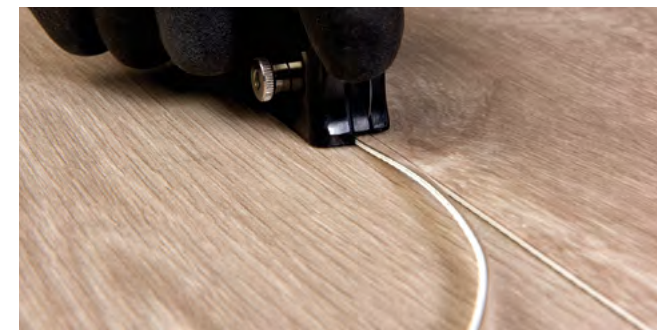

Figure 6.5 Cutting in the seams



Further information on seam cutting and cold welding can be found in Section nine.

6.11 PATTERN TEMPLATE METHOD

NEW BUILDINGS

Consider coming to an agreement with the main contractor to fit fixtures such as WCs & sinks after the vinyl has been laid.

Areas which call for a considerable amount of fitting around obstacles, or which are too confined to lay down a sheet for fitting by normal methods, can be dealt with by templating the floor in felt paper.

- ▶ Dry fit the area with felt paper, leaving a gap of 15mm to 20mm around obstructions and walls.
- ▶ Draw around the fittings using a compass set at 25mm. Mark the template 'This Side Up'.
- ▶ Place the sheet in a larger area with the face uppermost.
- ▶ Place the template on top ensuring the direction of decoration on the sheet is correct.
- ▶ Secure the template firmly in position and, with a pair of scribers set at 25mm, mark the position of all obstacles using the template as a guide.
- ▶ Using a sharp trimming knife, cut the sheet to the scribed lines and fit into position.

NOTE Do not use the felt paper template as an underlay.

6.12 LOOSE LAY VINYL TILE AND PLANK

6.13 RECEIPT & STORAGE

On receipt of tiles or planks:

- ▶ Check that colours correspond to those ordered, that quantities are correct and there is no obvious damage.
- ▶ In particular, check that tiles are from one batch, if that was requested on the order.
- ▶ On arrival at site, the tiles should be stored, together with the adhesive, at a minimum temperature of 18°C for at least 48 hours prior to laying.
- ▶ Under normal conditions (outside temperature above 10°C) the tiles should be off-loaded from the pallet and stacked no more than **five** boxes high during the conditioning period. The stacks should be arranged to allow the air to circulate around the stack on all sides.
- ▶ In cold weather (outside temperature below 10°C) the boxes should be opened and the tiles spread out in the area where they are to be installed permitting the tiles to acclimatize more quickly.
- ▶ To achieve best results, site conditions should be as described in BS 8203 or prevailing local/national standards. A working temperature of between 18°C and 27°C is required for 48 hours prior to, and during the laying period and for 48 hours afterwards.

6.14 LOOSE LAY CONDITIONING

The temperature should be constant and not vary more than 2°C. Conditioning areas and laying areas should be of similar temperature, to prevent thermally induced dimensional changes.

6.15 PRIOR TO INSTALLATION (UNDERFLOOR HEATING)

- ▶ On installations where underfloor heating is used, the system should be fully tested and commissioned prior to the flooring installation commencing.
- ▶ Underfloor Heating systems should be switched off and be fully cooled for a minimum of 48 hours prior to the installation commencing.
- ▶ The system should remain off and fully cooled during the installation and for a minimum of 48 hours afterwards. It should then be slowly brought back up to the working temperature incrementally over several days. A maximum floor temperature of 27°C should never be exceeded.

6.16 PREPARATION OF WORK AREA

The work area should now be prepared to receive the vinyl tiles.

- ▶ Ensure all other trades have completed their work and removed all their equipment and materials.
- ▶ Remove all debris and sweep or vacuum the whole floor area.
- ▶ Check the condition of the subfloor and make good as necessary.
- ▶ Commencement of work is deemed by many as acceptance of the site conditions as suitable for laying floor coverings.

6.17 LAYOUT OF LOOSE LAY VINYL TILES

Although many floor layers regard vinyl tiles as being easier to lay than vinyl sheet, the layout of the tiles can be critical to the success of the installation. The regular form of tiles, especially when laid in contrasting colours, can accentuate deviations in the building line, emphasizing the need for detailed planning of the layout.

Many floor layers start in the main doorway, believing that the initial impression when entering a room is most important. However, working from the centre of the room and loose laying tiles to check the layout will make the final appearance correct from any viewpoint. This is of particular importance when incorporating a geometric design into a floor.

- ▶ Cut with a sharp knife from the face side, ensuring the cut is 90°, by scoring twice, the 2nd score cuts the glass fibre reinforcement layer. Open up the cut by bending the tile, and then finish the cut from the back side.
- ▶ A minimum 2mm expansion gap must be left between the product and the wall or other fixed components such as door frames or heating pipes.
- ▶ When installing in an entrance area; larger-scale heavy commercial environments or any areas where heavy foot traffic or regular rolling loads can be expected, a suitable double sided contact tape or suitable tackifier release system, can be used to avoid movement. If tape is used it should be applied diagonally, running one way only, across the full area at 500mm centres. This will ensure that all tiles are secured to the substrate.
- ▶ Areas larger than 10m x 10m, require the inclusion of a 5mm expansion joint. A suitable expansion joint cover should be used. Expansion joints should be included for every subsequent 100m².

Find out more about the **Layout of Loose Lay** on the **4 day Polyflor Floor Laying Course**

- ▶ As extremes of temperature can occur between day and night time, temperatures will fluctuate. It is essential that the effects of these fluctuations be avoided. Installations that are directly adjacent to south facing and full height windows should be covered both during the conditioning and installation periods to minimise this effect. This includes covering patio doors, bi-fold doors and conservatory or orangery windows. Complaints arising from the failure to correctly condition the tiles and planks, which result in shrinkage or lipping, will not be accepted by Polyflor Ltd.

6.18 MEASURING AND MARKING OUT

KEY POINT

When setting out planks/tiles, always start from the centre of the room

- ▶ In order to produce the optimum appearance carefully plan and set out the tiles. It is advantageous to dry lay a section of the floor so that it can be determined whether the appearance of the pattern is acceptable and also to ensure any graining/texture within individual tiles is correct.
- ▶ Traditionally the starting point for tiles is the centre of the room.
- ▶ Before adhering confirm that the overall appearance of the flooring is acceptable.
- ▶ If the room is irregular in shape it may be necessary to square up the tiles off the most important wall or a specific feature.
- ▶ In areas directly adjacent to full height windows, conservatories, orangeries, etc., or areas exposed to direct sunlight for prolonged periods of time or where high temperature fluctuations can occur Polyflor recommend that a suitable high temperature adhesive selected from Polyflor's approved adhesive list should be used to fix tiles/planks in these localised areas only. Contact [Polyflor CTSD](#) on +44 (0) 161 767 1912 for further advice.
- ▶ Prior to laying the first plank, ensure all cuts are of an acceptable length (min. 150mm).
- ▶ As the planks are not required to be laid 'in bond' in the length, it is possible to begin the installation from an end wall.
- ▶ Planks must be staggered to obtain a random finish, however ensure that plank ends are not within 150mm of adjacent planks.

6.18.1 Straight Tiling – Setting Out

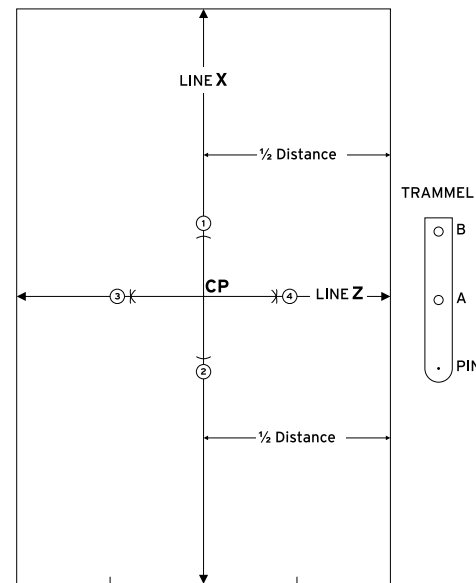

Figure 6.6 Marking out straight tiling

6.18.2 Diagonal Tiling – Setting Out

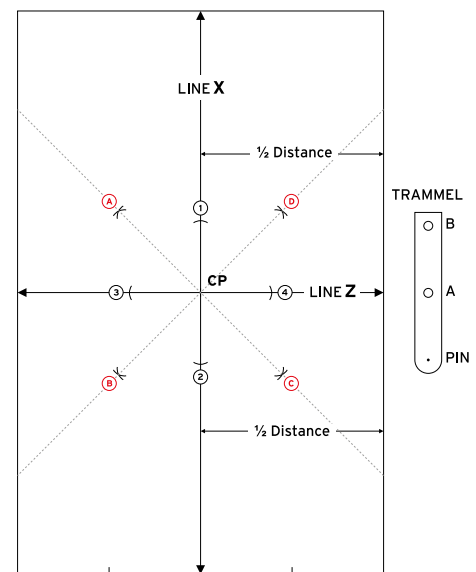

Figure 6.7 Marking out diagonal tiling

- ▶ Measure the room to be laid, in both directions, including any alcoves.
- ▶ Mark a centre line X. Ensure it is central to the room dimensions.
- ▶ Loose lay tiles to ensure there are no small cuts at the perimeter. If small strips are evident, move the centre line across half a tile in either direction to create an acceptable sized cut.
- ▶ Find the centre of line X and mark the Centre Point (CP).
- ▶ Mark arcs 1 & 2 at equal distances from CP on the centre line using point A on your trammel.
- ▶ With points 1 & 2 as centres, use point B on your trammel to draw further arcs intersecting at 3 & 4.
- ▶ Strike a line through point 3 & 4 ensuring it passes through CP.
- ▶ Line Z is now 90° to line X.
- ▶ Double check using the 3,4,5 method.

- ▶ Set out as overleaf for straight tiling. Ensure both lines are at 90° to each other.
- ▶ At CP (Centre Point), use point B on your trammel to mark arcs at 1, 2, 3 and 4.
- ▶ With points 1 & 3 as centres using point B on your trammel draw arcs to intersect each other at A.
- ▶ With points 2 & 4 as centres using point B on your trammel draw arcs to intersect each other at C.
- ▶ Strike a chalk line from wall to wall through points A & C; if no error has been made, this line will pass through CP.
- ▶ With points 1 & 4 as centres using point B on your trammel draw arcs to intersect each other at D.
- ▶ With points 2 & 3 as centres using point B on your trammel draw arcs to intersect each other at B.
- ▶ Strike a chalk line from wall to wall through points B & D; if no error has been made, this line should pass through CP.
- ▶ Double check using the 3,4,5 method.

6.19 CUTTING THE PERIMETER TILES

Two techniques are commonly used for cutting perimeter tiles. The choice is mainly dependent upon the run out of the wall.

6.19.1 Overlapping Method

Used when there is little or no run out of the abutting wall.

- ▶ Place the tile to be cut exactly over the last tile laid, ensuring the colour is correct and the decoration runs the correct way.
- ▶ Place another full tile on top of the tile to be cut with its 'top edge' against the wall or set-in coved skirting (Figure 6.8).



Figure 6.8 Measuring using an overlapping tile

- ▶ Scribe a line onto the tile to be cut, using the 'bottom edge' of the top tile as a guide.
- ▶ Cut the tile to the scribed line, loose lay into position and check the fit. Repeat along the whole wall.

6.19.2 Scriber Method

Used when the wall run out is quite severe or when the wall profile cannot be picked up using a straight edge.

KEY POINT

Use either Overlapping or Scriber Method to fit around projections such as door frames.

- ▶ Place the tile to be cut exactly over the last tile laid; ensuring the colour is correct and the decoration runs the correct way.
- ▶ Set the bar scriber to the size of the tile being laid.
- ▶ Trace the profile of the wall on to the tile to be cut, ensuring the bar scriber is kept upright and square to the edge of the tile.
- ▶ Cut the tile to the scribed line, loose lay into position and check the fit. Repeat along the whole wall.

Both the Overlapping and Scriber Methods can be used to fit around projections such as door frames. Similarly, a template can be made or a profile gauge containing movable pins can be used for awkward shapes.

6.20 INSTALLING TILES IN LARGE AREAS

Maintaining a clearly defined straight line over long distances can be difficult and often leads to inaccuracies. To eliminate this problem, an alternative technique is used when laying tiles in large areas:

- ▶ Establish the central starting point, as described previously, minimising small cuts on perimeter tiles.

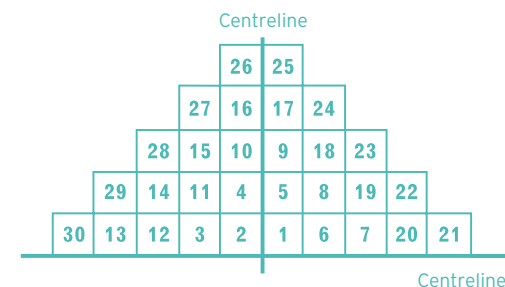

Figure 6.9 Pyramid layout

- ▶ Lay the first pyramid of tiles from the centrelines, using the sequence shown in Figure 6.9. Ensure a close bond is maintained at all times.
- ▶ Repeat this sequence on the opposite side of the centreline. Continue working in larger and larger pyramids, until only the perimeter tiles require fitting.

NOTE Construction of a pyramid should always start at the centre of the baseline, working in the same sequence as shown in Figure 6.9.

6.21 INTERLOCKING TILES AND PLANK SYSTEMS

6.22 GENERAL INFORMATION

When installing an interlocking product always follow current local and national standards for the installation of floor coverings. The best current installation practice incorporating the latest technical developments should be employed. The preparation of the subfloor, the installation of the floor covering and the measures taken to safeguard value are key factors in ensuring optimum suitability and performance of resilient floor coverings.

6.23 RECEIPT & STORAGE

On receipt of materials:

- ▶ Check that colours correspond to those ordered and that there is no damage or visual defects in the material.
- ▶ In particular, check that the material is from one batch. Claims for visual defects can only be accepted prior to installation and cutting.
- ▶ The Interlocking plank/tile system must be protected against dirt and moisture during storage.
- ▶ During storage and installation the room temperature should be 20°C (minimum 15°C) and have a relative humidity of 50-60%.
- ▶ Prior to laying the floor, open the boxes and place them in the room in which they are to be installed for a minimum of 48 hours BEFORE the installation commences, so the material can acclimatise itself.
- ▶ Boxes should never be stacked greater than **three** boxes high.

KEY POINT

Interlocking tiles & planks should not be stacked more than **THREE** boxes high.

6.24 PREPARATION OF SUBFLOORS

- ▶ The Interlocking plank/tile system can be laid over :
 - Mineral subfloors prepared in accordance with accepted trade standards. It must be clean, durable, permanently dry and flat.
 - Existing floor coverings of ceramic, vinyl and linoleum as long as they are clean, flat and there is no dampness under the floor covering.
 - Wooden floors, floorboards and chipboard floors as long as they are flat, firmly fastened and free of protruding nails etc.
- ▶ Joints in the subfloor must be evened out as a rule the maximum deviation permitted would be 3mm when measured under a 2m straight edge. Higher deviation can cause permanent damage to the locking mechanism.

KEY POINT

Carpets and soft floorings are **unsuitable** as a base for the installation of the Interlocking plank/tile system. These will need to be removed.

- ▶ Solid subfloors should demonstrate a maximum damp content of 75% RH before the installation can begin. Residual moisture contents for solid cementitious and screeded subfloors max. 2.0 CM % With underfloor heating 1.8 CM %.
- ▶ Anhydrite floor max. 0.5 CM % (With underfloor heating 0.3 CM %).

NOTE Once the subfloor has been prepared the Interlocking plank/tile flooring **must** be laid over the **recommended Polyflor Underlay**.



Figure 6.10 Polyflor Underlay

6.25 PRIOR TO INSTALLATION (UNDERFLOOR HEATING)

Where underfloor heating has been installed within the subfloor:

- ▶ The system should be fully tested and commissioned prior to the flooring installation commencing.
- ▶ Underfloor Heating systems should be switched off and be fully cooled for a minimum of 48 hours prior to the installation commencing. The system should remain off and fully cooled during the time of the entire installation and for a minimum of 48 hours afterwards. Then over several days slowly and incrementally brought back up to the working temperature.
- ▶ A maximum subfloor temperature of 27°C should never be exceeded.

6.26 CONDITIONING

- ▶ The Interlocking plank/tile system must be protected against dirt and moisture both before and during the installation.
- ▶ The climatic conditions acceptable for the installation of interlocking planks/tiles are:
 - Floor temperature > 15°C
 - Room temperature > 18°C
 - Air Relative humidity < 50-60%

6.27 INSTALLATION INSTRUCTIONS

During storage and installation the room temperature should be 20°C (minimum 15°C) and have a relative humidity of 50-60%.

In the event of extended deviations from the aforementioned room conditions < 30% or > 80% for relative humidity or temperatures of (< 10°C or > 30°C) a change in the dimensions, gap formation is a typical characteristic for this kind of product; the expansion gap required can therefore increase from those described herein.

In such instances please seek advice from **Polyflor CTSD** by calling +44 (0) 161 767 1912.

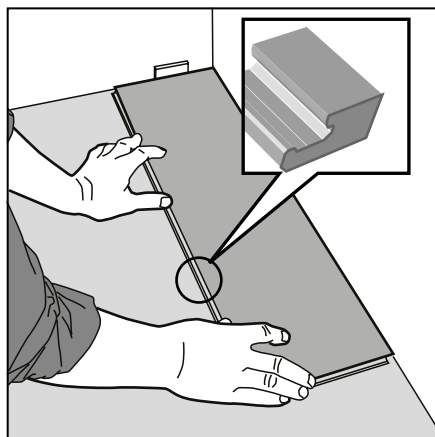

Figure 6.11 First plank, first row

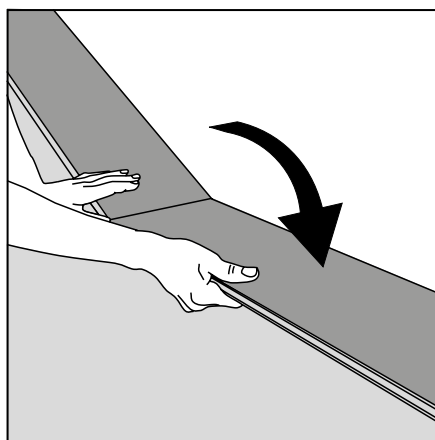

Figure 6.12 Second plank, first row

6.27.1 First tile/plank, first row

- ▶ The boards are laid without glue/adhesive. Start to lay the floor in the left-hand corner of the room.
- ▶ A minimum expansion gap of 4mm should be left around the installation perimeter and anything protruding from the subfloor.
- ▶ For larger installations an expansion gap of 1mm per linear metre of room length should be used. e.g. a room 8m x4m would require an expansion gap of 8mm around the entire perimeter of the room and around anything protruding from the floor.

- ▶ Use small offcuts of the tile/plank as spacers between the planks and the walls to help achieve the correct size gap.

6.27.2 Second tile/plank, second row

- ▶ Press the short end of the next tile/plank at an angle to the first one, and then lay down. Complete the first row in the same way.

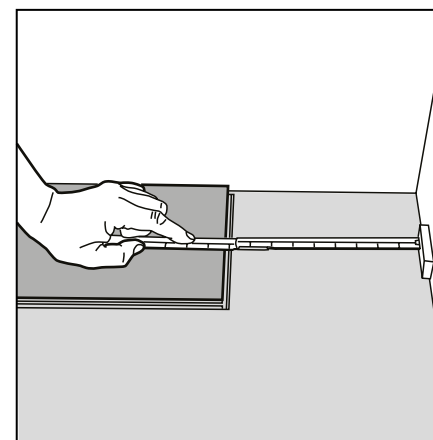

Figure 6.13 Last plank, first row

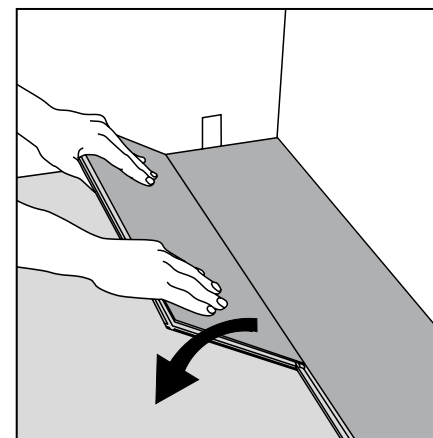

Figure 6.14 First Plank second row

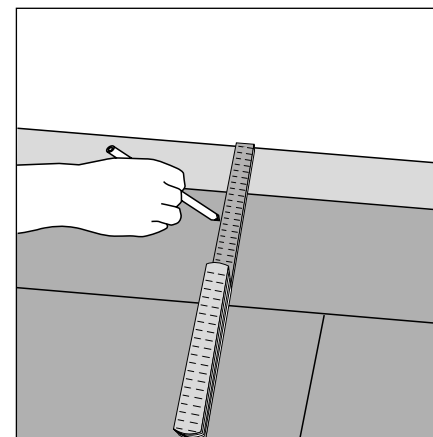

Figure 6.15 Managing uneven walls

6.27.3 Last tile/plank, first row

- ▶ Insert correct sized spacer between the end of the first row and the wall to ensure the correct expansion gap is left.
- ▶ Measure the length of the last tile/plank to fit.
- ▶ Cut the last panel to correct length, recommended minimum length is 350mm.

6.27.4 First tile/plank second row

- ▶ Insert spacer between the end of the first row and the wall. (Expansion gap).
- ▶ Start the new row with the leftover piece from the last row.
- ▶ Insert the tile/plank at an angle against the plank in the previous row, press forward and fold down at the same time.
- ▶ Always try to stagger the short joints approx. 150mm from a short joint in the previous row.

6.27.5 Managing uneven walls

- ▶ If the wall is uneven, the floorboards should be marked or scribed to its contours.
- ▶ Mark the floorboards with the contour of the wall. Don't forget to include the required expansion gap to the wall.
- ▶ To cut the planks to fit the last row, position them one at a time directly over the previous row in the direction you'll be laying them.
- ▶ Hold them firmly in place. Then line up a third board on top.
- ▶ Use the edge of this board to mark the cutting line with a pencil on the board beneath. Remember to allow for the expansion gap (Figure 6.15).

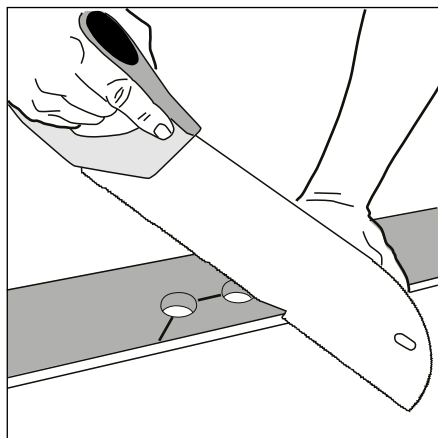

Figure 6.16 Radiator pipes

6.27.6 Radiator Pipes (Figure 6.16 & 6.17)

- ▶ Principle cut out – mark the centre of the holes on both the long and short sides using a carpenter's square and a pencil.
- ▶ Where the marks cross drill a pilot hole using a thin #6 or #8 drill bit. Further drill the hole with a spade bit wide enough to accommodate both the diameter of the pipe and the required expansion gap.
- ▶ Cut around as shown with a saw or with a sharp utility knife. Install the floor plank.
- ▶ If necessary, put a bead of contact glue on the cut piece and replace. Insert a spacer directly behind the inserted piece to wedge it in place ensuring that the correct sized expansion gap has been left. Leave this in place until the glue has hardened.

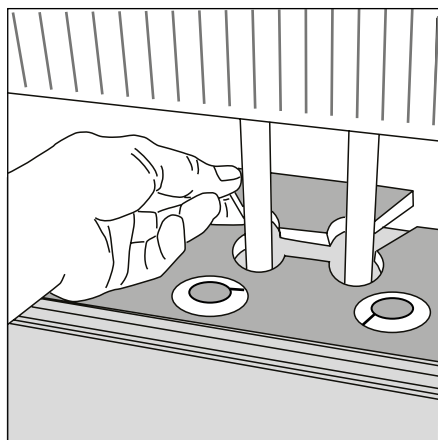

Figure 6.17 Radiator pipes

6.27.7 Door Frames (Figure 6.18)

- ▶ When installing Interlocking plank/tile around a door frame, cut into the door frame with a handsaw, using an off cut plank/tile and some underlay as a guide for the height and the amount to trim off the door frame.
- ▶ Slide the cut piece under the door frame.

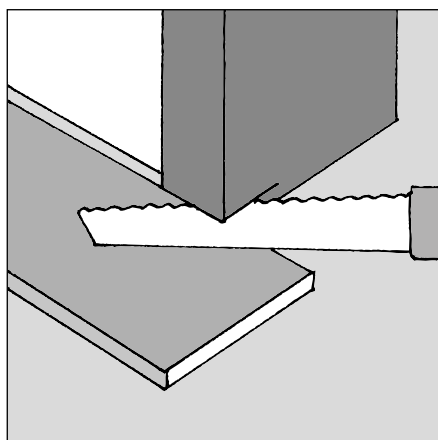

Figure 6.18 Door frames

6.27.8 Adjoining other floor coverings

- ▶ When adjoining other floor coverings, finish the Interlocking plank/tile in the doorway.
- ▶ An appropriate expansion gap should be left between the Interlocking plank/tile and the adjoining floor covering.
- ▶ This can be covered using a suitable threshold or diminishing strip later.

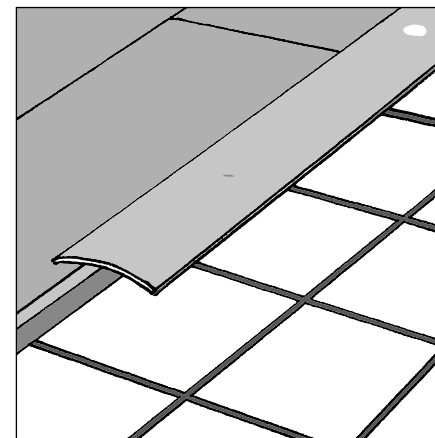

Figure 6.19 Threshold strip

6.27.9 Installing across multiple rooms (Figure 6.19)

- ▶ Finish the Interlocking plank/tile in the doorway on either side and allow a break between the two floors of double that left around the perimeter.
- ▶ A suitable threshold strip can then be installed to cover the resultant gap. Place two small off cut pieces of Interlocking plank/tile back to back to gauge the correct gap size.
- ▶ When installing a threshold never mechanically fix direct to the Interlocking plank/tile; instead affix to the subfloor and allow sufficient space between the top edge of the threshold and the surface of the Interlocking plank/tile so as to allow movement into the expansion gap.

6.28 COMPLETION WORK

Interlocking plank/tile are designed as floating floors hence the floor covering can be walked on directly after it is installed.

- ▶ Remove all the spacers and wedges from the edge expansion gaps.
- ▶ Skirting boards, base boards, quadrants or scotia can be used to conceal the expansion gap, however they should never be fitted directly onto the surface of the interlocking plank/tile.
- ▶ Leave a small gap between the two, allowing for the natural movement of the plank underneath the skirting or scotia.

NOTE Shades that illustrate heavily embossed surfaces will require a slightly larger gap between the surface of the plank/tile and the underside of the skirting/scotia etc. to accommodate free movement into the expansion gap.



- CONTENTS
- INTRODUCTION
- SUBFLOORS
- SHEET
- TILES
- LVT
- LOOSE LAY
- ESD
- POLYGLAD
- WELDING
- BORDERS
- FINISHES
- CHEMICALS
- TEMPERATURES
- MAINTENANCE